



M30-THRU BSA

English Threaded BB
FOR M30-THRU ROAD or MTN Cranks

SAFETY INFORMATION - READ BEFORE RIDE

Since specific tools and experience are necessary for proper installation, it is recommended that the product be installed by a qualified bicycle technician.

Read the service instructions of your crank carefully prior to installing the parts. Loose, worn or damaged parts may cause riding problems and serious injury may occur as a result. If installation and adjustments are not carried out correctly, the chain may come off and this may cause you to fall off the bicycle which could result in serious injury. **Read these instructions carefully, and keep them for later use.**

- Ensure that the frame shell is clean.
- Before riding the bicycle, check that there is no play or looseness in the bottom bracket connection. Be sure to retighten the crankarms and pedals at periodic intervals.
- If you feel any looseness or 'play' in the bearings, the bottom bracket should be inspected/replaced.
- Be sure to read the instructions for your front chainrings/crank in conjunction with these service instructions.
- **Do not wash the bottom bracket with high-pressure jets of water.**
- For maximum performance it is required to remove and periodically inspect/clean your Praxis Works bottom bracket.
- **Parts are not guaranteed against natural wear and tear resulting from normal use.**
- For any questions regarding methods of installation, adjustment, maintenance or operation, please contact a professional bicycle dealer or call Praxis Works.
- Praxis Works assumes no responsibility for damages or injury related to improperly installed components.

READ THE STEP-BY-STEP INSTRUCTIONS THAT ARE PROVIDED ON THE OTHER SIDE.

For the latest instructions and knowledge base updates: <https://praxiscycles.com/tech-docs/>

WARRANTY

- Praxis Works Bottom Bracket products are warranted to be free from defects in materials or workmanship for two years after original purchase. The warranty is non-transferable and valid to the original purchaser of the product only.
- Any attempt to modify the product in any way such as drilling, grinding or painting will void the warranty.
- This warranty is not valid for "abused" or neglected products, or products that are damaged by improper installation.
- If a defect is found, our entire liability and your sole remedy shall be, at our option, free repair or replacement of the Praxis product.
- Except as expressly required by law, Praxis Works shall not be held liable for any indirect, special, or consequential damages.

THIS WRITTEN EXPRESS WARRANTY IS IN LIEU OF ALL OTHER WARRANTIES, IMPLIED OR EXPRESSED. This warranty gives you specific legal rights, and you may also have other rights which vary state to state. **For more information on warranty policy and instructions for completing a warranty claim, check out the Full Warranty Policy found at our website. www.praxis-works.com**

M30-THRU BSA Compatibility and Spec	
CRANKSET	Compatible Praxis M30-THRU & other-brand cranks (30mm DRIVE/30mm NON-DRIVE)
FRAME SHELL	BSA 68mm Road Frames BSA 68/73mm MTN Frames

REQUIRED TOOLS

- One Praxis M30 BB Tool
- Anti-Seize Compound
- 3/8" Drive Torque Wrench
- Waterproof Grease

Included Parts		
Number	Part	Qty
1.	30mm ID X 1mm Dust Cover	1
2.	30mm ID X 2mm Dust Cover	1
3.	LEFT/NON-DRIVE Cup with 30mm ID Bearing	1
4.	BB Cup Spacer for 68mm MTN ONLY	1
5.	Sleeve (internal dust/moisture seal)	1
6.	BB Cup Spacer for 68mm MTN ONLY	1
7.	RIGHT/DRIVE Cup with 30mm ID Bearing	1
8.	30mm ID X 2mm Dust Cover	1
9.	30mm ID X 4mm Dust Cover	1
10.	30mm ID X 6mm Dust Cover	1



TOOLS REQUIRED



**SOCKET
WRENCH**



**TORQUE
WRENCH**

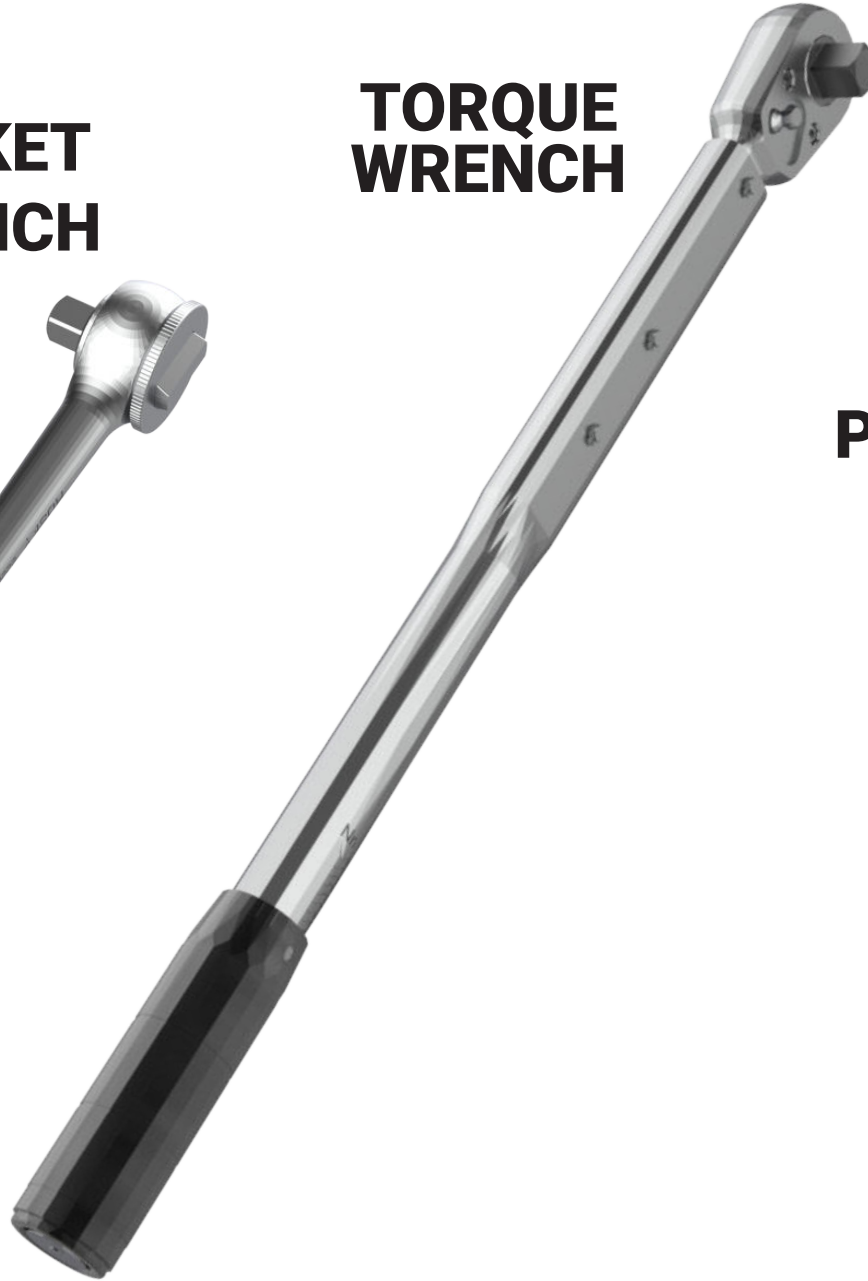

**SINGLE
PRAXIS M30 TOOL**

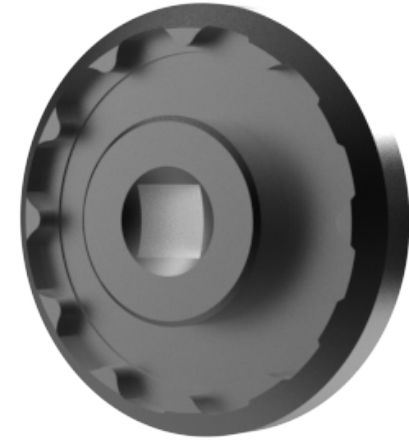

BOTTOM BRACKET INSTALLATION

VIP : The included 2 Cup Spacers are **ONLY** used for MTN bike cranks on 68mm wide frames!

2.5mm
Cup Spacers



BB Cup
Frame Prep

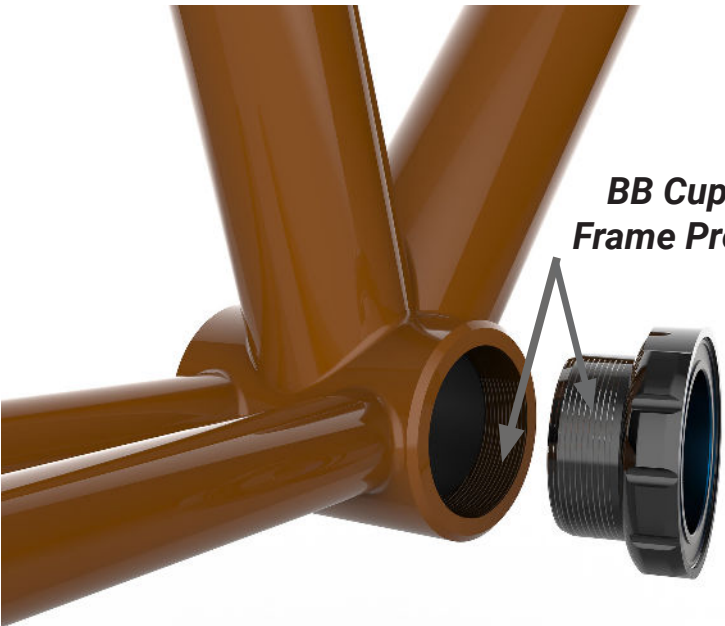

1. Apply grease or anti-sieze to the frame & BB cup threads
2. Locate, read and follow the directional arrows on the cups
3. Thread the Right/Drive cup into the frame's Right/Drive side
4. Thread the Left/Non-Drive cup with the attached moisture seal into the frame's Left/Non-Drive side
5. Finish by tightening both cups to 40Nm of torque with a **Praxis M30 Tool**
6. **See next page** to find correct Dust Covers for your crank. Lightly grease underside of Dust Covers and place them over bearings **with logos facing outward**.
Now you can install your crank

Torque both cups
to 40Nm with
Praxis M30 Tool



30MM

30MM

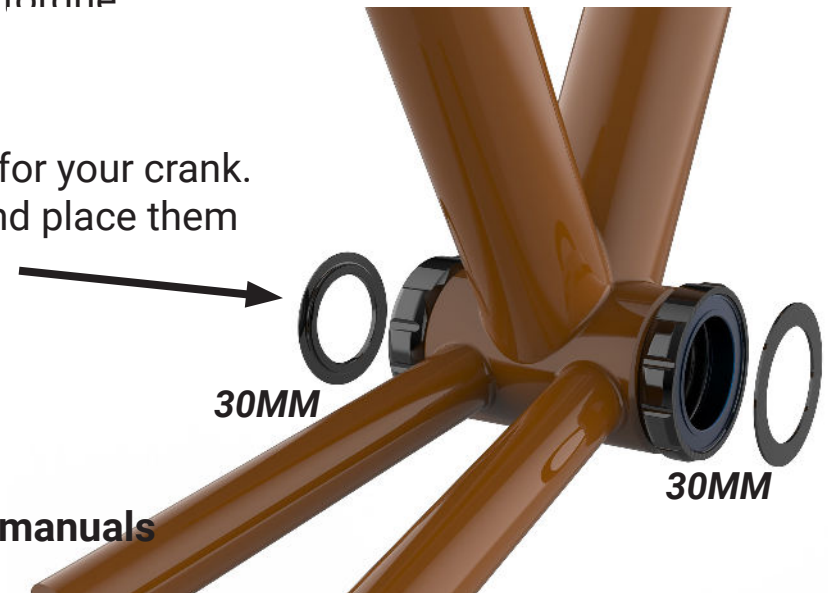

*** CRANK INSTALLATION ***

Please see PRAXIS CRANK instructions at www.praxiscycles.com/manuals

BB DUST COVER SETUP

**LEFT/NON-DRIVE
30mm I.D.**



**RIGHT/DRIVE
30mm I.D.**

**NEXT PAGE FOR
DUST COVER GUIDE**

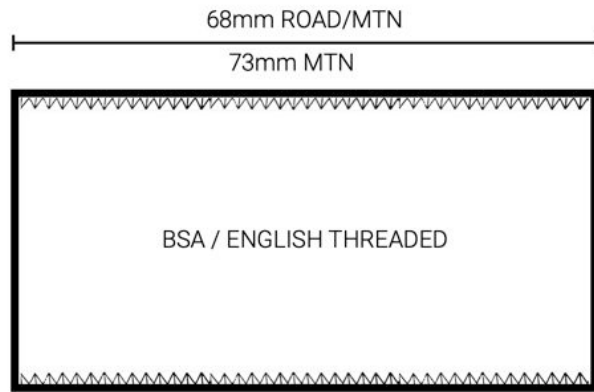

REFERENCE - FRAME BB SPECS

BB DUST COVER GUIDE

ROAD M30-THRU	WIDTH	CRANK	LEFT 30MM COVER	LEFT CUP SPACER	RIGHT CUP SPACER	RIGHT 30MM COVER
* BSA	68	DOON	<i>Preload Ring Only</i>	-	-	3mm
		OTHER BRAND	2mm	-	-	2mm
T47 E.B.	68	DOON	<i>Preload Ring Only</i>	-	-	3mm
		OTHER BRAND	2mm	-	-	2mm
T47 I.B.	85.5	DOON	<i>Preload Ring Only</i>	-	-	3mm
		OTHER BRAND	2mm	-	-	2mm
T47 Asym	76.75	DOON	<i>Preload Ring Only</i>	-	-	3mm
		OTHER BRAND	2mm	-	-	2mm
BB86	86.5	DOON	<i>Preload Ring Only</i>	-	-	3mm
		OTHER BRAND	2mm	-	-	2mm
386EVO	86.5	DOON	<i>Preload Ring Only</i>	-	-	3mm
		OTHER BRAND	2mm	-	-	2mm
BB30/PF30	68	DOON	<i>Preload Ring Only</i>	-	-	3mm
		OTHER BRAND	2mm	-	-	2mm
BBRight	79	DOON	<i>Preload Ring Only</i>	-	-	3mm
		OTHER BRAND	2mm	-	-	2mm

MTN M30-THRU	WIDTH	CRANK	LEFT 30MM COVER	LEFT CUP SPACER	RIGHT CUP SPACER	RIGHT 30MM COVER
* BSA	68	GEN1 LYFT	<i>Preload Ring Only</i>	2.5	2.5	2mm
		GEN2 LYFT	<i>Preload Ring Only</i>	2.5	2.5	6mm
		OTHER BRAND	2mm	2.5	2.5	2mm
	73	GEN1 LYFT	<i>Preload Ring Only</i>	-	-	2mm
		GEN2 LYFT	<i>Preload Ring Only</i>	-	-	6mm
		OTHER BRAND	2mm	-	-	2mm
T47 E.B.	73	GEN1 LYFT	<i>Preload Ring Only</i>	-	-	2mm
		GEN2 LYFT	<i>Preload Ring Only</i>	-	-	6mm
		OTHR BRAND	2mm	-	-	2mm
T47 I.B.	89.5	GEN1 LYFT	<i>Preload Ring Only</i>	-	-	2mm
		GEN2 LYFT	<i>Preload Ring Only</i>	-	-	6mm
		OTHER BRAND	2mm	-	-	2mm
BB90	89.5	GEN1 LYFT	2mm	-	-	2mm
		GEN2 LYFT	1mm	-	-	6mm
		OTHER BRAND	2mm	-	-	2mm
BB92	92	GEN1 LYFT	<i>Preload Ring Only</i>	-	-	1mm
		GEN2 LYFT	1mm	-	-	4mm
		OTHER BRAND	2mm	-	-	2mm
BB30/PF30	73	GEN1 LYFT	<i>Preload Ring Only</i>	-	-	2mm
		GEN2 LYFT	<i>Preload Ring Only</i>	-	-	6mm
		OTHER BRAND	2mm	-	-	2mm