

PEDAL

SAFETY INFORMATION - READ BEFORE RIDE

Since specific tools and experience are necessary for proper installation, it is recommended that the product be installed by a qualified bicycle technician.

Read these pedal service instructions carefully before installing. Loose, worn or damaged parts may cause problems and serious injury may occur as a result. If installation and adjustments are not performed correctly, the pedals may come off and this may cause you to fall off the bicycle which could result in serious injury.

Read these instructions carefully, and keep them for later use.

- Be careful not to let your clothing get caught in the chain while riding, otherwise you may fall off the bicycle.
- Check that the chain tension is correct and that the chain is not damaged. If the tension is too weak or the chain is damaged, the chain should be replaced or else it may break and you may fall off the bicycle.
- Use a torque wrench to check the final tightening torque of the pedals. Furthermore, after riding approximately 60 miles (100 km), use a torque wrench to re-check the tightening torques.
- Before riding the bicycle, check that there is no play or looseness in the pedal/axle connection. Also, be sure to retighten pedals to 35-40 Nm at periodic intervals.
- If you feel any looseness or 'play' in the bearings, the crank / Pedals should be inspected/replaced.
- **Parts are not guaranteed against natural wear or deterioration resulting from normal use.**
- For any questions regarding methods of installation, adjustment, maintenance or operation, please contact a professional bicycle dealer or call Praxis Works.
- Praxis Works assumes no responsibility for damages or injury related to improperly installed components.

READ THE STEP BY STEP INSTALLATION INSTRUCTIONS PROVIDED ON THE OTHER SIDE.

WARRANTY

- **Praxis Works products are warranted to be free from defects in materials or workmanship for two years after original purchase. The warranty is non-transferable and valid to the original purchaser of the product only.**
- Any attempt to modify the product in any way such as drilling, grinding or painting will void the warranty.
- This warranty is not valid for "abused" or neglected products, or products that are damaged by improper installation.
- If a defect is found, our entire liability and your sole remedy shall be, at Praxis Works option, free repair or replacement of the Praxis product.
- Except as expressly required by law, Praxis Works shall not be held liable for any indirect, special, or consequential damages.

THIS WRITTEN EXPRESS WARRANTY IS IN LIEU OF ALL OTHER WARRANTIES, IMPLIED OR EXPRESSED. This warranty gives you specific legal rights, and you may also have other rights which vary state to state. **For more information on warranty policy and instructions for completing a warranty claim, check out the Full Warranty Policy found at our website.**

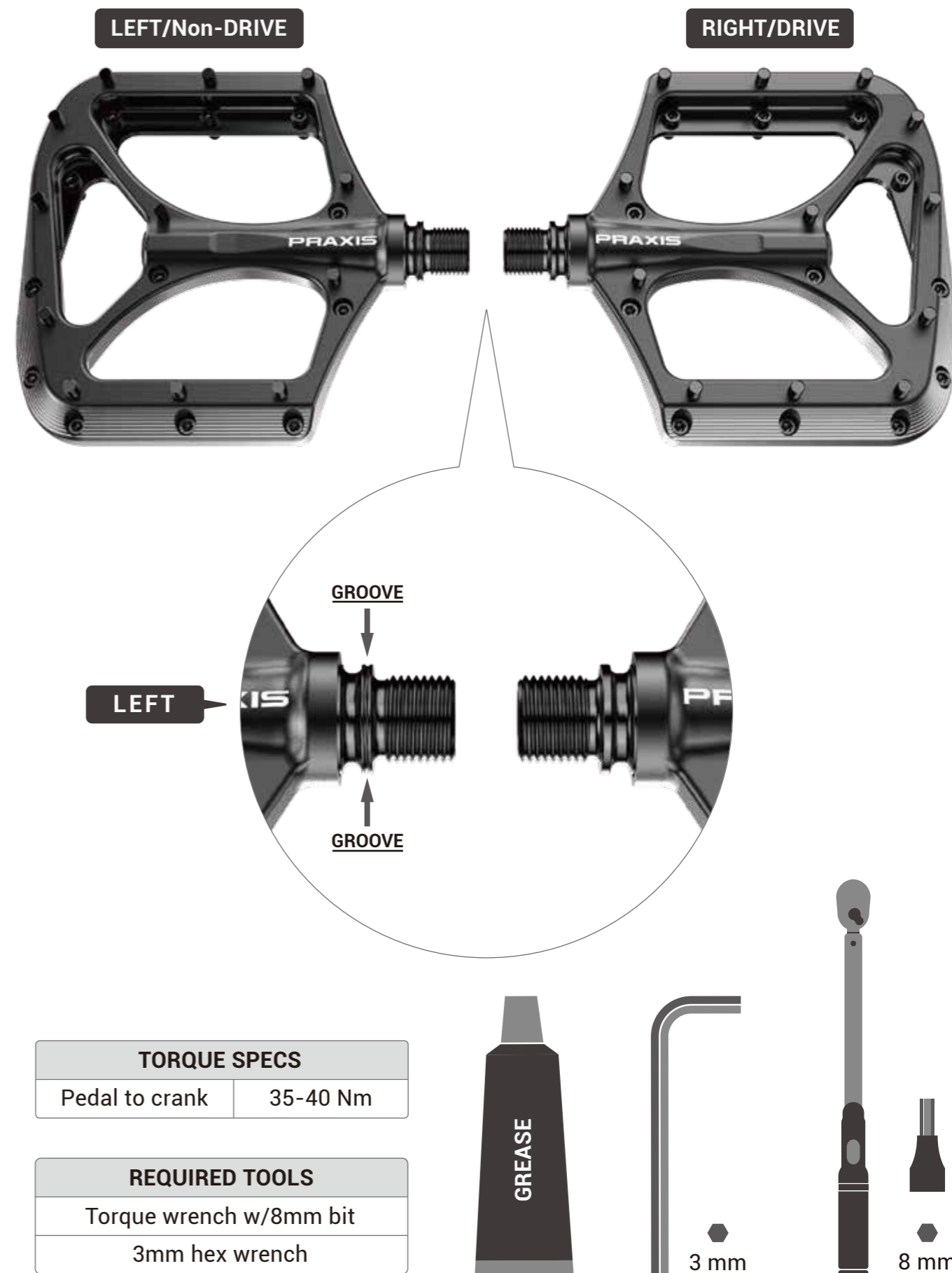

PEDAL INSTALLATION

BEFORE YOU START

- **Pedal Washers** : not required but may use $\leq 2\text{mm}$ pedal washers **per side**.
- **Carbon Cranks** : If using pedal washers, check to make sure the pedal washer **does not** touch or interfere with carbon at pedal insert.



INSTALL

1. Dab grease on pedal threads
2. Thread LEFT pedal into LEFT crank - Tighten with 8mm Allen and Torque to **35-40 Nm**
3. Thread RIGHT pedal into RIGHT crank - Tighten with 8mm Allen and Torque to **35-40 Nm**
4. Make sure both pedal flanges are flush with crank arm surface. There should be no gap between pedal flange and crank arm.
5. Now go Ride !

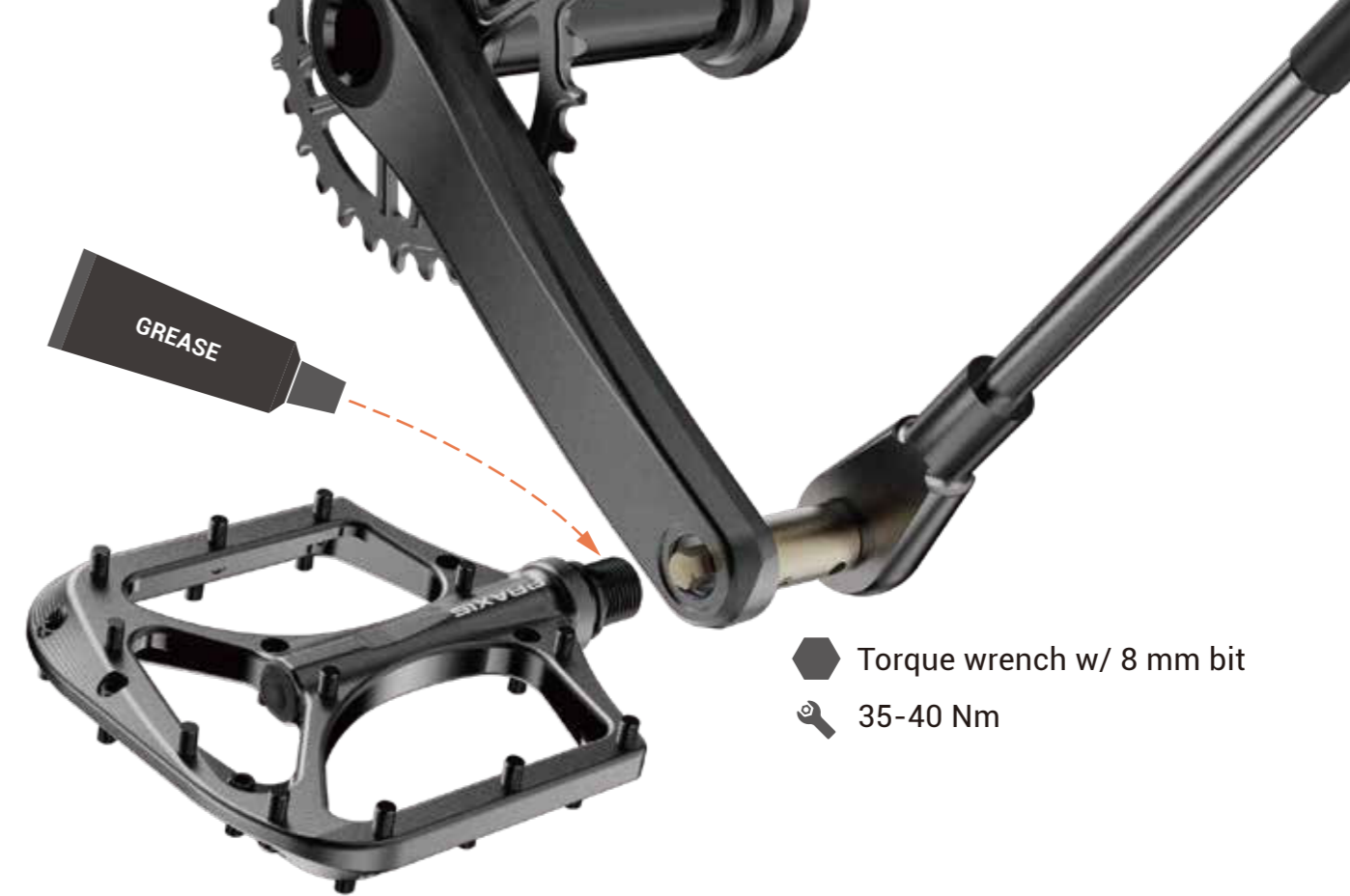

WARNING : These pedals are not made for use on indoor exercise bicycles or equipment.



 Torque wrench w/ 8 mm bit
 35-40 Nm

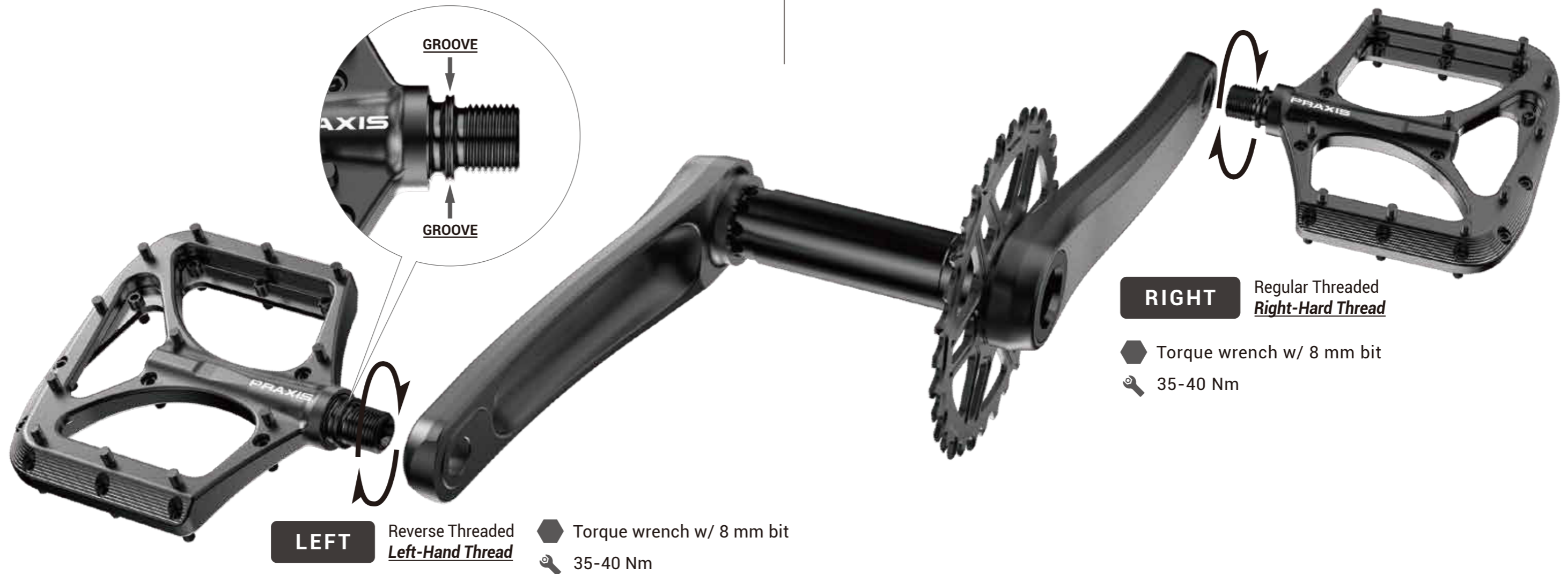

EXPLODED VIEWS

AXLE KIT / REBUILD KIT

- Axle
- Axle Screw



- V-Ring
- Igus Bushing
- Bearings
- Bearings Spacer
- Axle Screw
- Axle Plug



3 mm
3 Nm

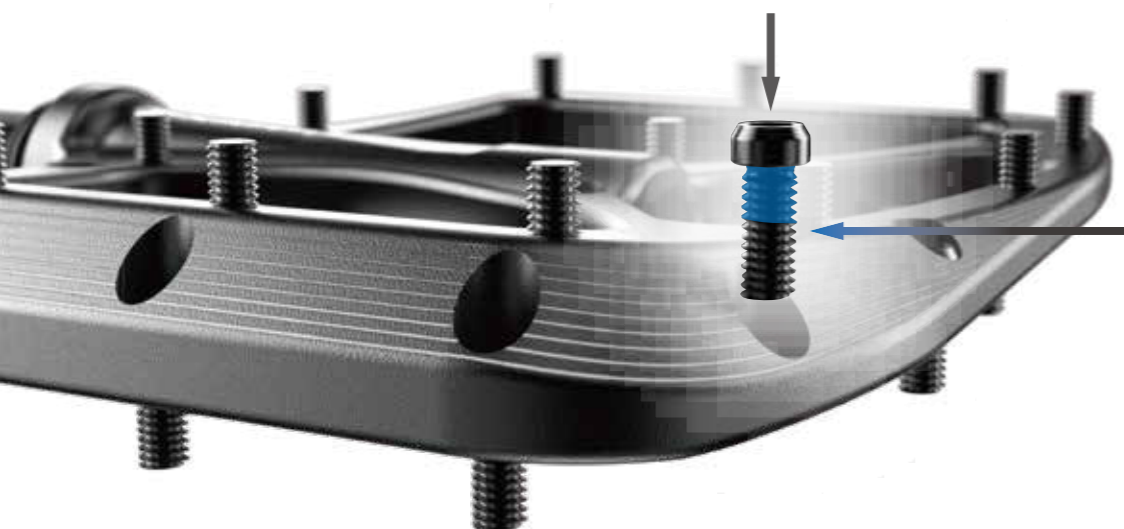

PINS - M4 THREADING
Use threadlocker!



REBUILD KIT
REBUILD KIT VIDEO

REBUILD KIT

Tools Needed

- 1 8mm Allen Key (any kind)
- 2 6mm Allen Key (at least 3.5" long or 6-9mm)
- 3 4mm Allen Key (at least 3" long or a 4-5mm)
- 4 3mm Allen Key (must have L-style, ball-end will make it easier)
- 5 Pick or small flat head screwdriver
- 6 Small hammer
- 7 Blue Loctite (if not using a rebuild kit and are planning on just performing a simple cleaning teardown and rebuild)
- 8 M13x1.5 or 1/2"-13 Tap (only if Igus bushing needs replacement)
- 9 Your favorite Marine grade grease

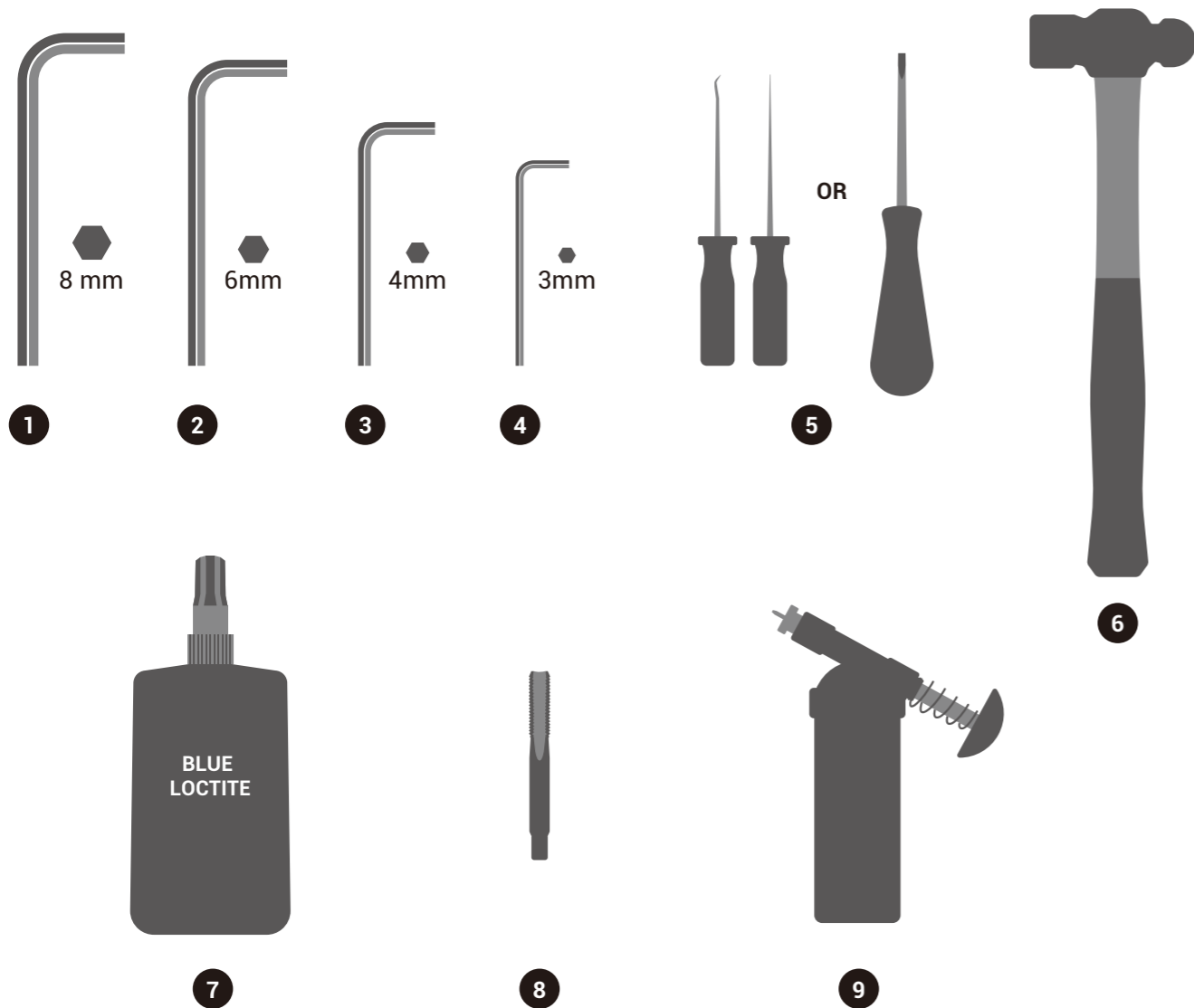

PRO TIPS FOR LH AND RH PEDAL IDENTIFICATION

- The following explains the descriptors used in this document for the identification and notation regarding LH and RH pedals.

- When sitting on your bike in riding position, imagine a line going down the length of your bike :

Left Hand Pedal

1. Left half of your bike is Left Hand (LH).
2. Also known as Non-Drive Side (NDS).
3. Pedal body has "Praxis" logo spelled left to right and is not upside down.
4. Annular groove on axle shoulder to indicate LH threads.

Right Hand Pedal

1. Right half of your bike is Right Hand (RH).
2. Also known as Drive Side (DS).
3. Pedal body has "Praxis" logo spelled left to right and is not upside down.

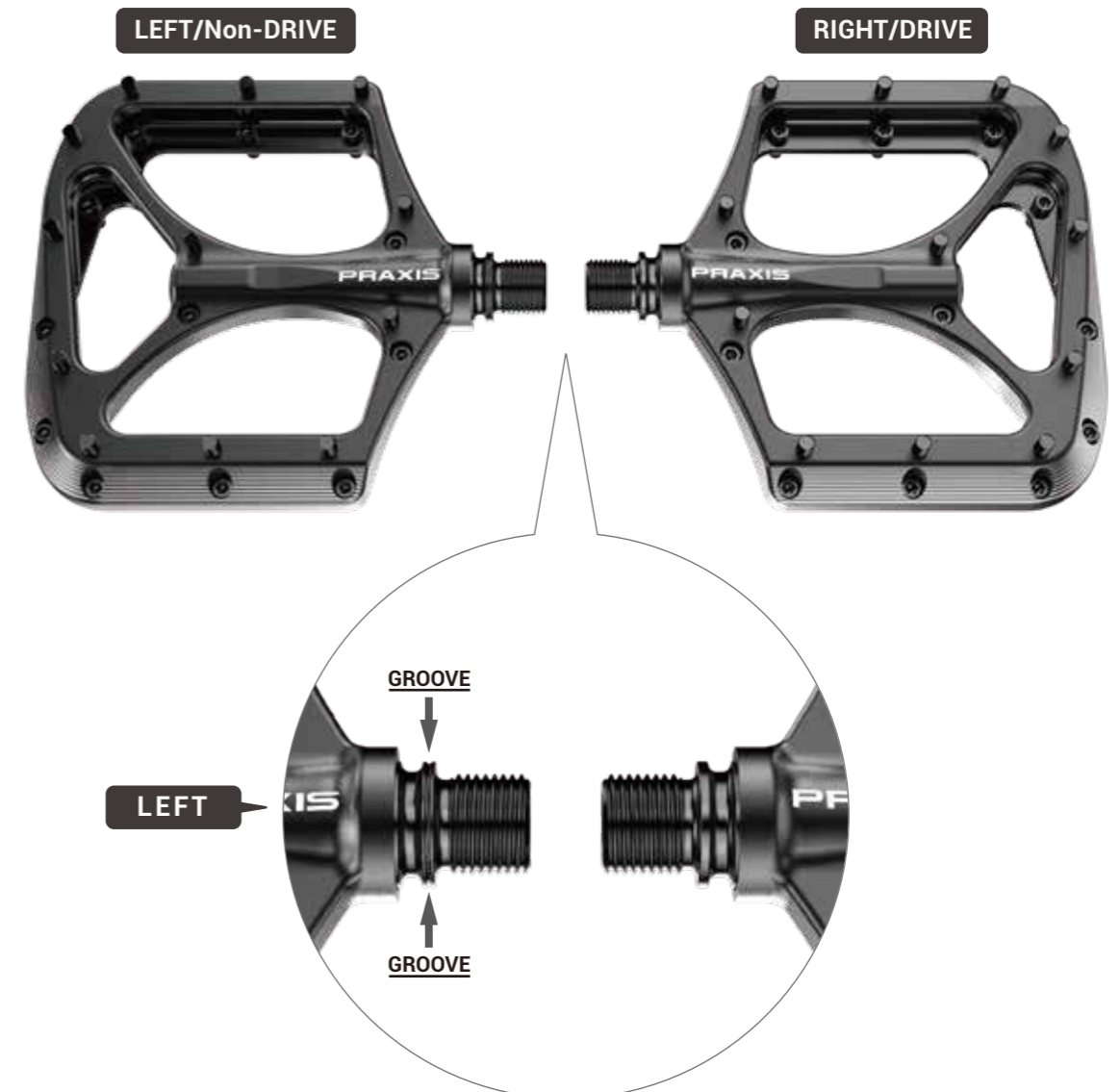

EXPLODED VIEW RIGHT PEDAL

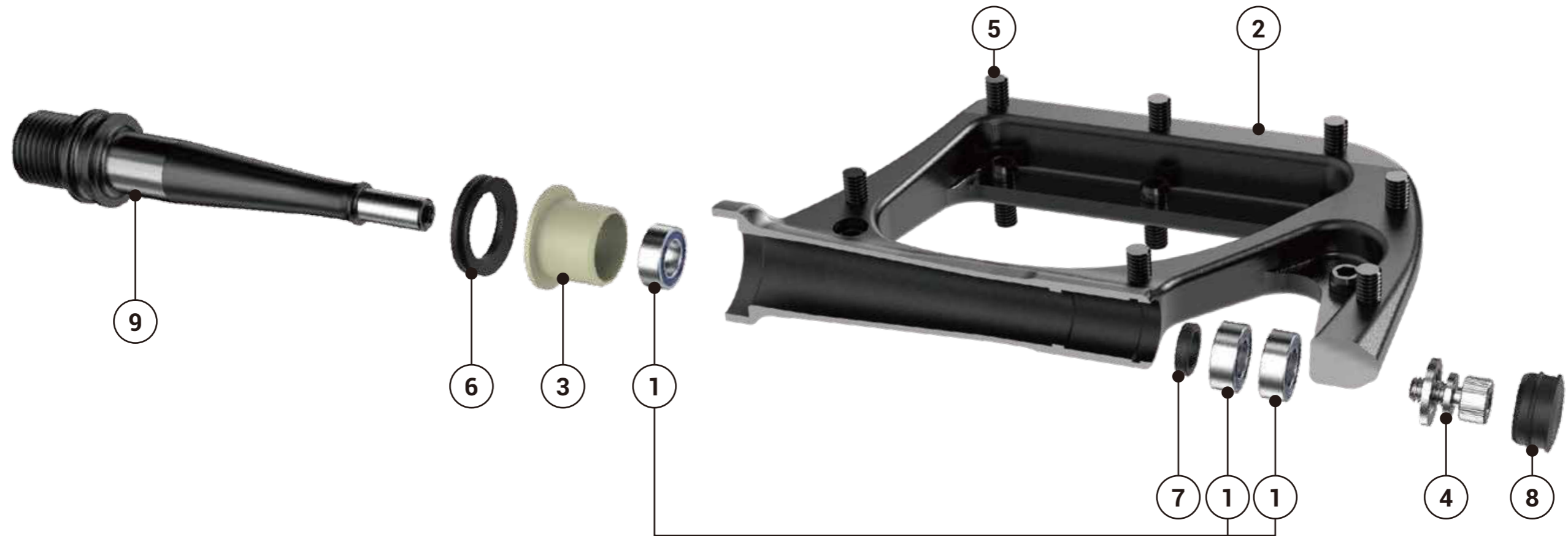

Index	Name	QTY	Service Kit Needed
①	Bearing MR116-2RS	3	Rebuild Kit
②	Pedal Body	1	N/A
③	Igus Bushing	1	Rebuild Kit
④	Axle Screw (LH Thread)	1	Rebuild and Axle Kit
⑤	Threaded Pins	24	Threaded or Smooth Pin Kit
⑥	V-Ring Seal	1	Rebuild Kit
⑦	Bearing Spacer	1	Rebuild Kit
⑧	Axle Plug	1	Rebuild Kit
⑨	RH Axle	1	Axle Kit

Left Pedal Specific Parts	
Part	Feature
LH Axle	<ul style="list-style-type: none"> Annular groove on shoulder LH external threads RH internal threads
LH Axle Screw	<ul style="list-style-type: none"> Smooth head RH threads
LH Pedal Body	Praxis logo is read left to right when positioned on left side of bike

Right Pedal Specific Parts	
Part	Feature
RH Axle	<ul style="list-style-type: none"> RH external threads LH internal threads
RH Axle Screw	<ul style="list-style-type: none"> Knurled head LH threads
RH Pedal Body	Praxis logo is read left to right when positioned on right side of bike

REMOVE FROM CRANKS

Remove the pedals Counterclockwise.



REMOVE RUBBER AXLE PLUG

1. Use the flat head screwdriver or pick to remove the rubber axle plug.
2. If you are just rebuilding pedal without replacing parts using our rebuild kit, make sure to not rip the axle plug upon removal.

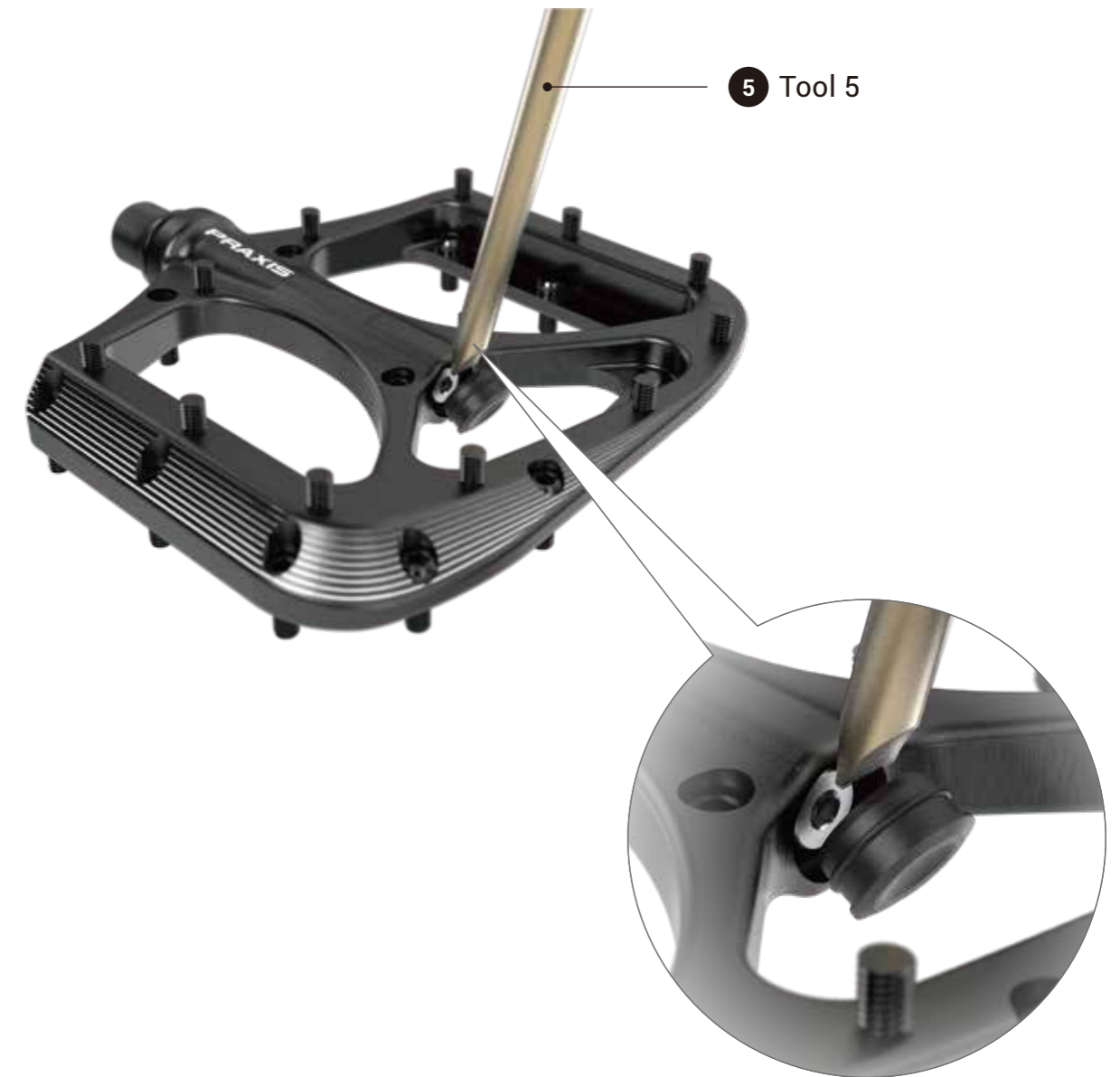

LOOSEN AXLE SCREW AND REMOVE AXLE - OPTION 1

1. Use 3mm Allen key and 8mm Allen key to loosen the axle.
2. Reminder :
 - LH pedal has regular right hand threads.
 - RH pedal has left hand threads.
3. Once small M4 screw is removed, axle is free to pull out towards the 8mm Allen key.
4. Note: Depending on how worn your pedals are, internal bearings may be tight to the spindle.
 - If so, follow option 2 on the following page.

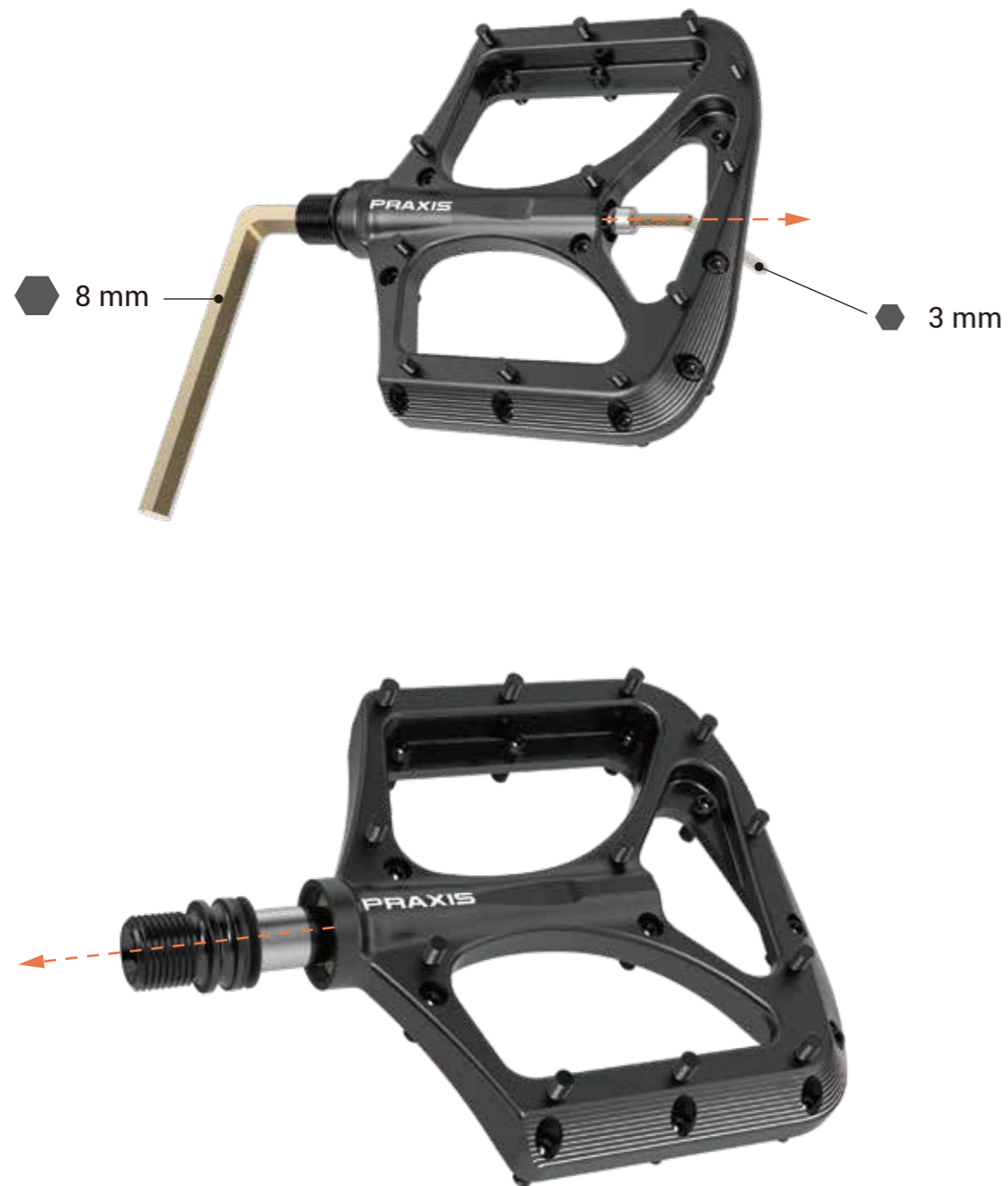

LOOSEN AXLE SCREW AND REMOVE AXLE - OPTION 2

1. Loosen M4 screw a little over halfway.
2. Then keep the 3mm Allen key installed and hit down on on the Allen key to knock the axle free from the bearings.
3. Continue until the axle is free.
4. Now fully remove axle and axle screw.

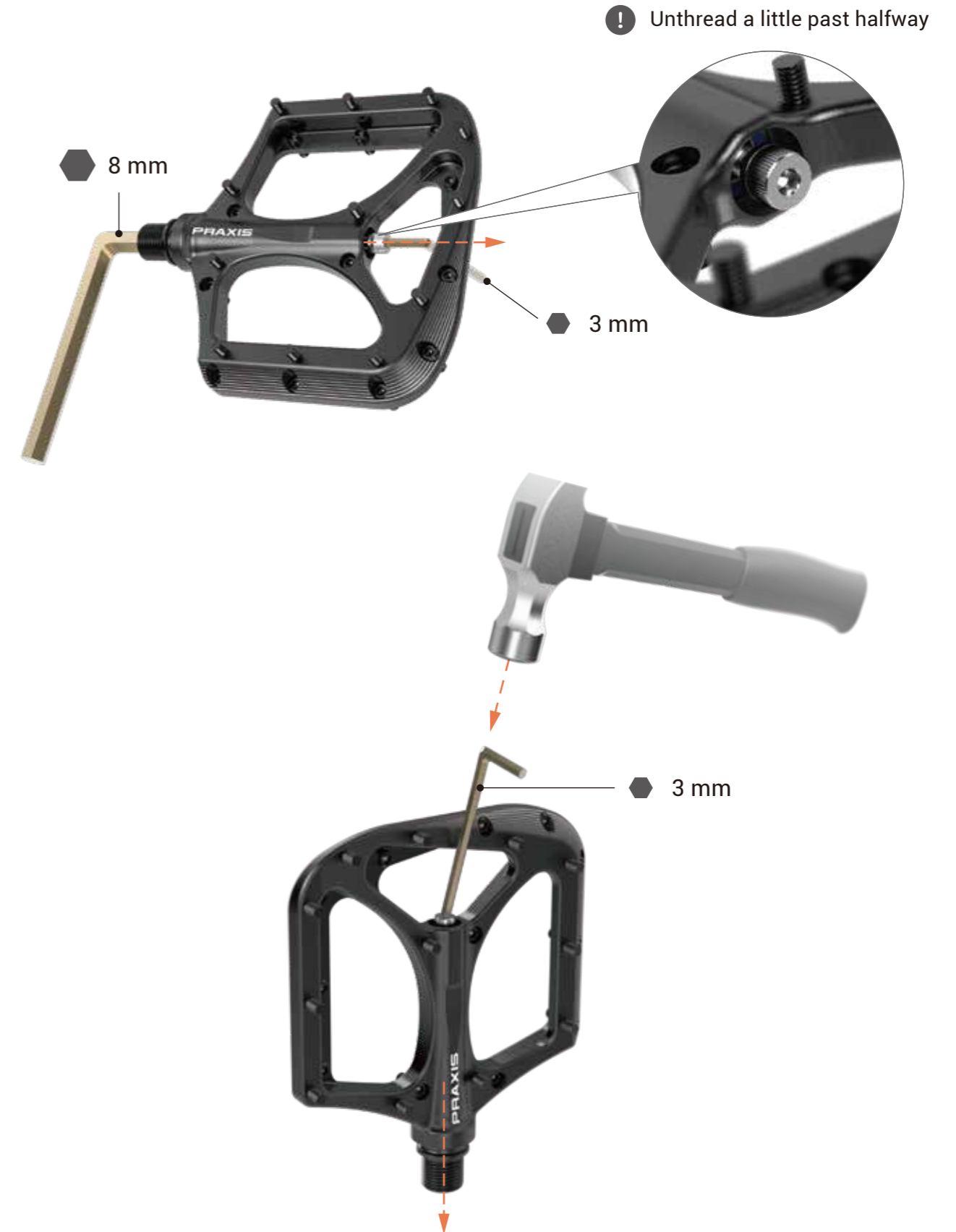

REMOVE V-RING, BEARINGS, AND BEARING SPACER

1. Referencing the exploded view, 1 bearing will come out towards the crank side, 2 bearings will come out to the outside.
 - A small black washer (bearing spacer) will fall out to either side as well.
2. Remove V-ring with fingers, pick, or flat head screwdriver.
3. If outer bearings haven't fallen out, use the M6 Allen key, punch, or screwdriver to knock the bearings out.

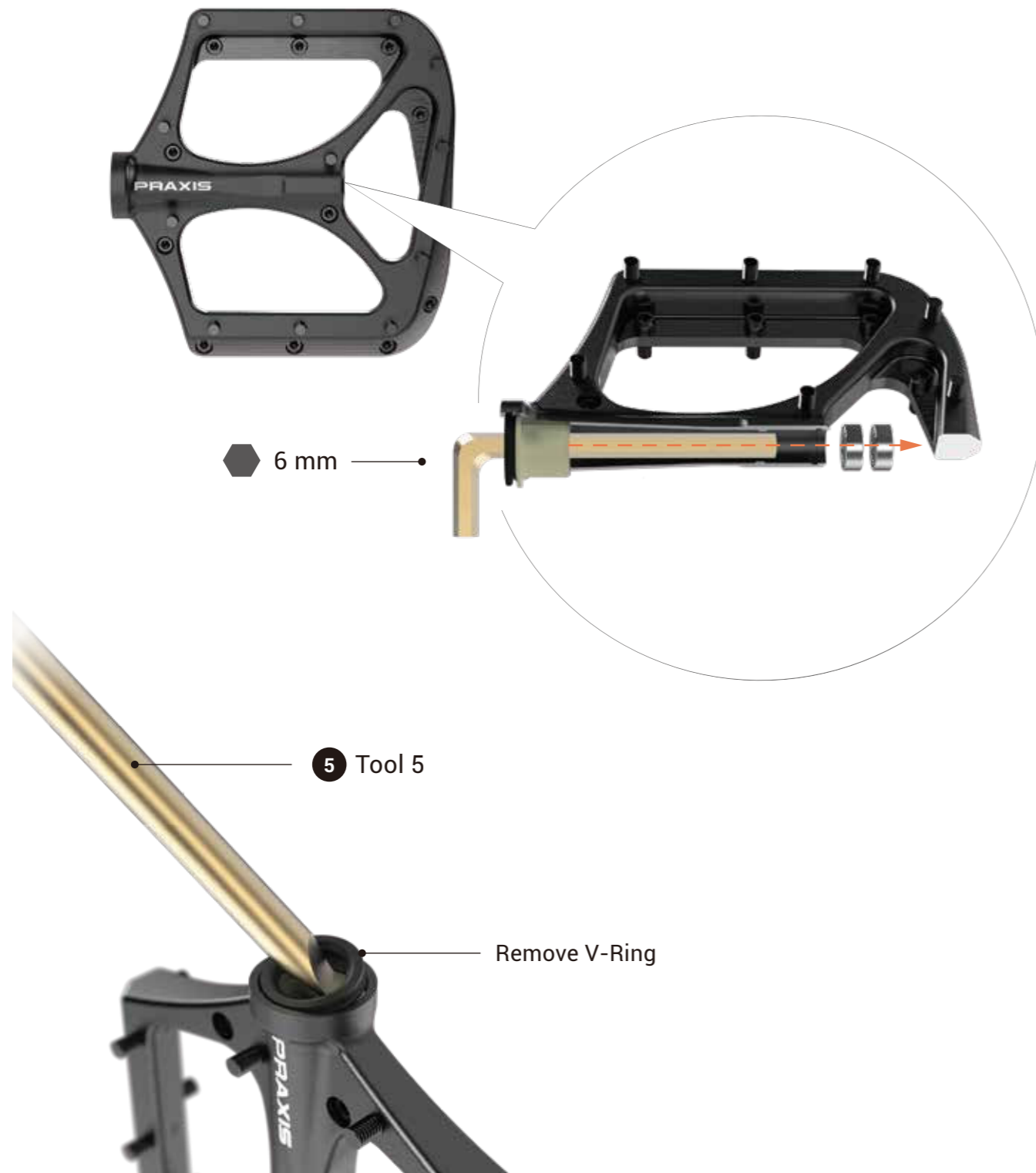

CLEAN AND INSPECT BEARINGS, BEARING SURFACES, AND IGUS BUSHING

1. Use rag to clean out inside of pedal.
2. If you are just doing a rebuild without replacing the parts using our rebuild kit :
 - Clean all parts of grease and dirt as you will be reusing them.
 - Inspect bearings to make sure they are spinning smoothly and seals are not damaged.
 - Inspect Igus bushing for any deep gouges.
 - Inspect V-ring to make sure it isn't torn anywhere.
 - If any of those parts are damaged, please purchase our rebuild kit to replace the worn items.
3. Inspect axle for any irregularities :
 - If the silver bearing surfaces are dirty, use a scouring pad, like green Scotch-Brite or light Emery cloth to clean the surfaces.



IGUS BUSHING REPLACEMENT (ONLY IF DAMAGED)

1. Igus bushings are a very low wear item, we include a set in each rebuild kit.
2. However, if you feel like you want to replace the Igus bushing or it is visibly damaged with gouges/scores, the process is simple.
3. Using 1 of the 2 tools :
 - M13x1.5 Tap
 - 1/2"-13 Tap
4. Put the tap in a vice or use a T-handle and hold pedal body by hand or in the vice.
5. Thread/cut into the Igus bushing at least half the distance of Igus bushing.
6. Rock pedal body side to side while pulling away from tap to remove the Igus bushing.

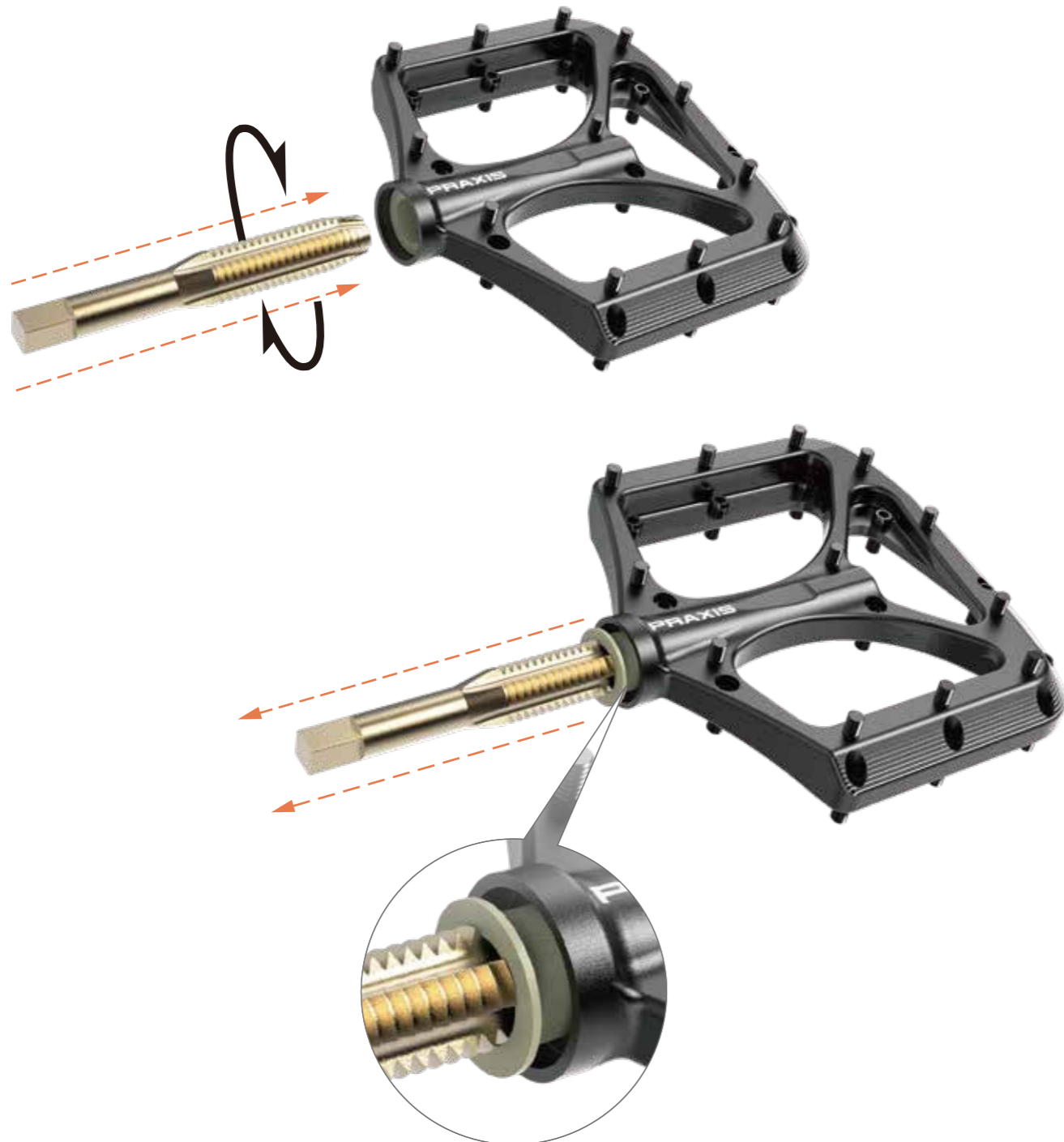

IGUS BUSHING INSTALLATION (ONLY IF IT WAS REMOVED)

1. Slip new Igus bushing onto bare axle. **Without grease**
2. Align axle into pedal body and tap the end of the spindle down with a hammer until the Igus bushing is fully seated.

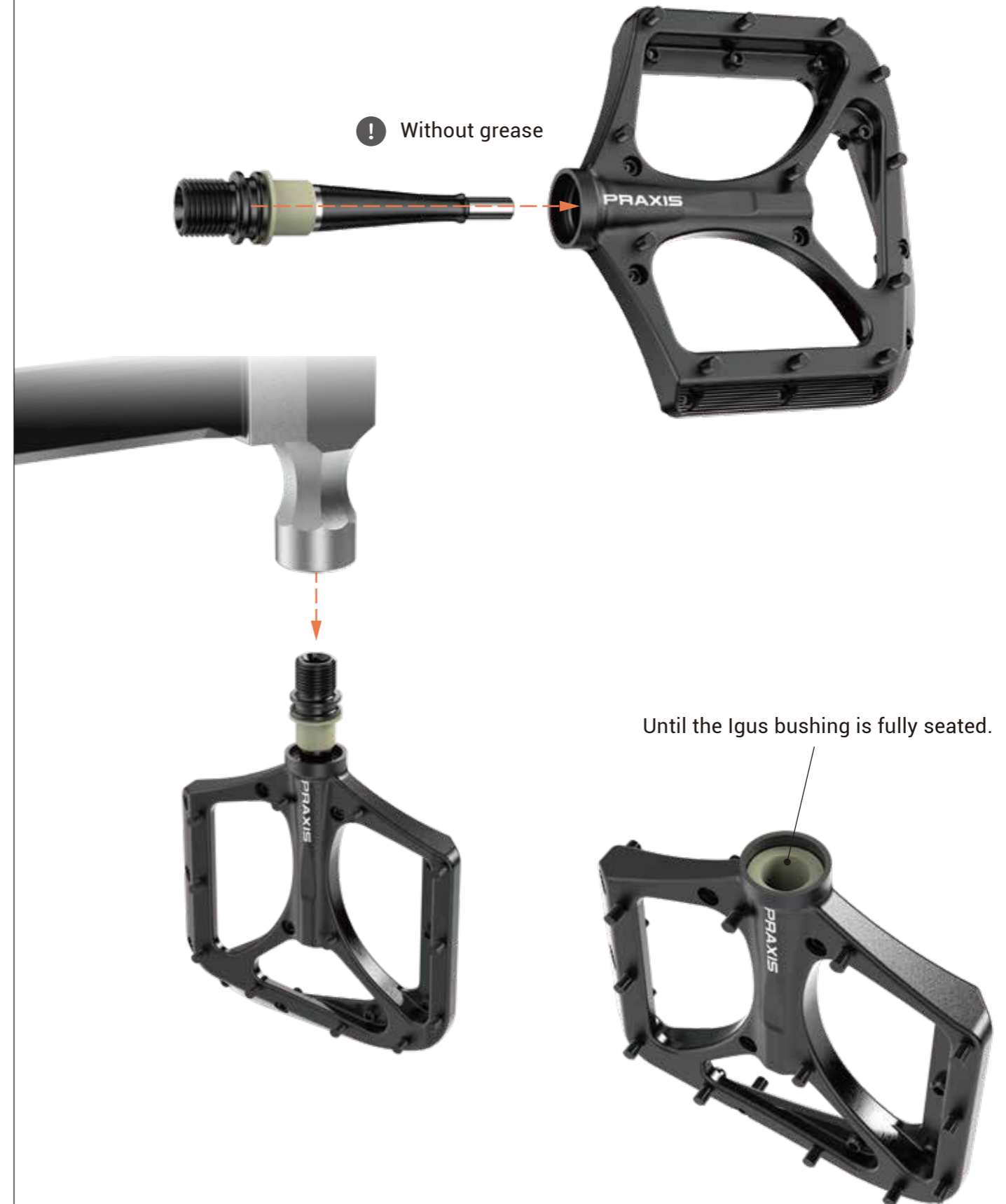

RE-ASSEMBLY : RH AXLE ASSEMBLY

1. Note: Process is the same regardless if you are doing a basic rebuild or replacing all wear items included in our rebuild kit.
2. Take RH axle and install V-ring with lip facing pedal body.
 - Refer to first few pages of manual for the correct way to identify LH and RH axles.
3. Lightly grease bearing surfaces and lipped side of V-ring.
4. Install inner bearing and bearing spacer onto axle.

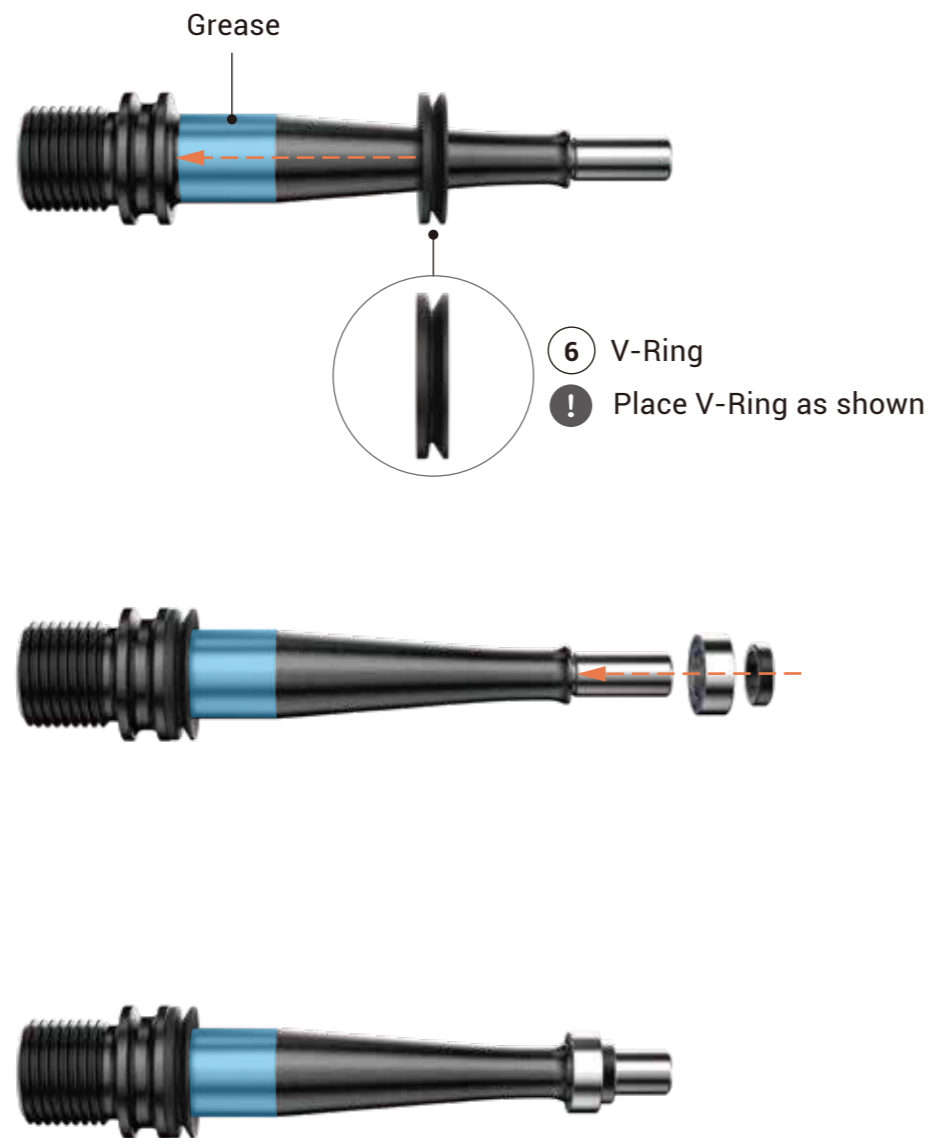

RE-ASSEMBLY : RH PEDAL BODY ASSEMBLY

1. Apply light grease to ID and OD of the 2 outer bearings.
2. Install them into outer bore of pedal body.
3. Use the flat head, or appropriate allen key to tap them into place.
4. Install the axle assembly into the pedal body.



RE-ASSEMBLY : RH PEDAL BODY ASSEMBLY

1. Apply light amount of blue loctite to axle screw if you are not using a rebuild kit during this process (new axle screws come with pre-applied loctite).
2. Thread into axle.
 - Reminder: since we are assembling RH pedal body, these are LH threads and you should be using the knurled head M4 axle screw.

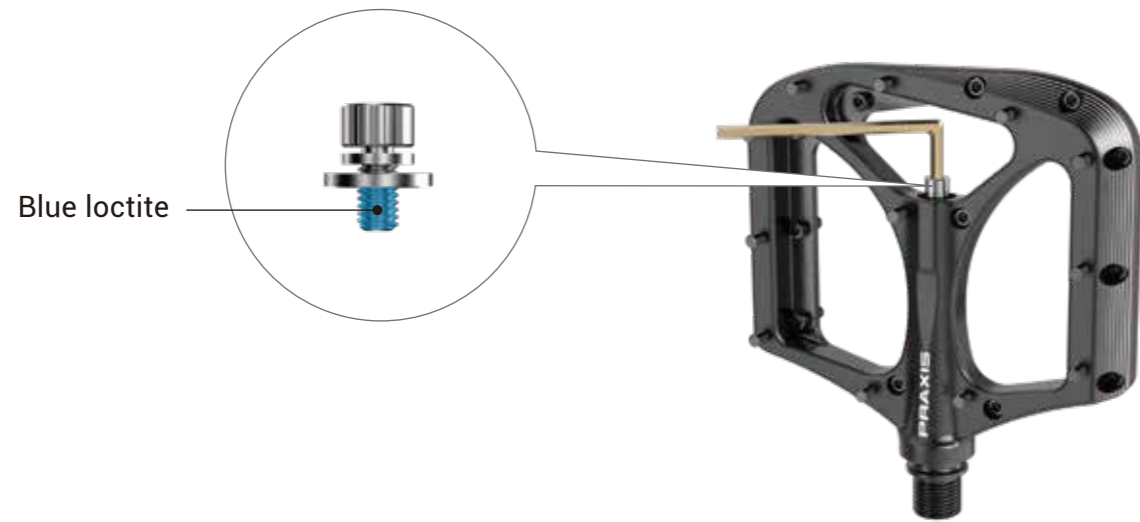

1. Set torque wrench to 4Nm.
2. Tighten 8mm end of axle with torque wrench while holding axle screw with the 3mm Allen key.
3. Check that your pedal spins smoothly and is not binding. (If it is binding, go back through the steps to make sure that everything is assembled correctly and that the individual bearings spin smoothly.)



RE-ASSEMBLY : RH PEDAL BODY ASSEMBLY

1. Install axle plug, aligning flat sections with the top and bottom of the pedal body.
2. Repeat the same process for the RH pedal assembly using the appropriate axle and axle bolt (refer to first pages on correct thread identification).
3. Get out there and ride !

